

# LCC Modelling System

## B 00-20 Bundle: Water tower

Bundle contains:

- 1x LCC 00-00
- 1x LCC 00-01
- 2x LCC 04-06
- 2x LCC 04-11
- 4x LCC 04-12
- 1x LCC 04-18
- 1x LCC 04-21
- 2x LCC 04-49
- 1x LCC 04-51
- 1x LCC 04-89
- 2x LCC 04-90
- 4x LCC 04-91
- 2x LCC 04-92

This kit includes elements which can be used to assemble a water tower.

For more instruction go to manual which you can download form our website [www.lcut.co.uk](http://www.lcut.co.uk)

**All drawings are not in scale.**

LCC Modelling System is flexible and you can make easy modification. Please visit our website at [www.lcut.co.uk](http://www.lcut.co.uk) to shop for additional LCC elements.

**!** We recommend PVA or any other paper/wood glue.

# LCC Modelling System

## B 00-20 Bundle: Water tower

Bundle contains:

- 1x LCC 00-00
- 1x LCC 00-01
- 2x LCC 04-06
- 2x LCC 04-11
- 4x LCC 04-12
- 1x LCC 04-18
- 1x LCC 04-21
- 2x LCC 04-49
- 1x LCC 04-51
- 1x LCC 04-89
- 2x LCC 04-90
- 4x LCC 04-91
- 2x LCC 04-92

This kit includes elements which can be used to assemble a water tower.

For more instruction go to manual which you can download form our website [www.lcut.co.uk](http://www.lcut.co.uk)

**All drawings are not in scale.**

LCC Modelling System is flexible and you can make easy modification. Please visit our website at [www.lcut.co.uk](http://www.lcut.co.uk) to shop for additional LCC elements.

**!** We recommend PVA or any other paper/wood glue.

FRONT AND BACK ELEVATIONS

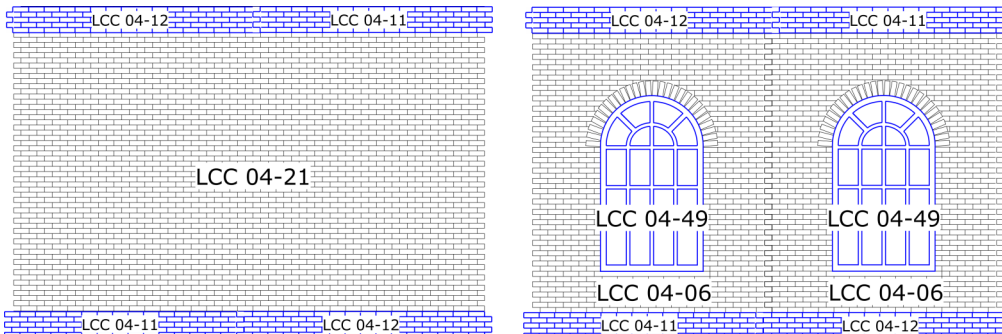

FRONT AND BACK ELEVATIONS

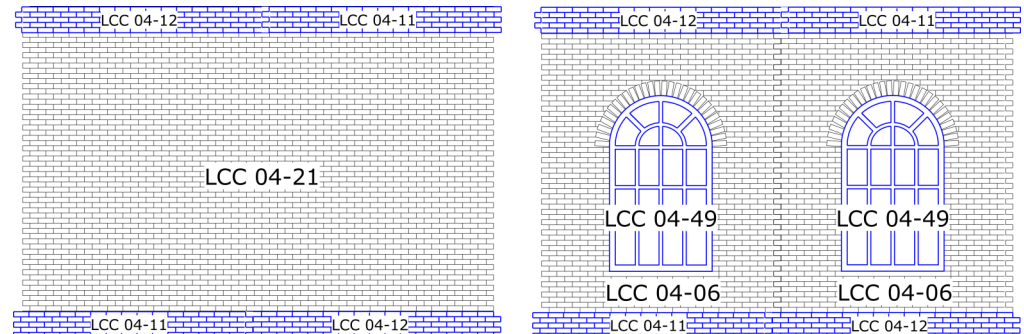

SIDE ELEVATIONS

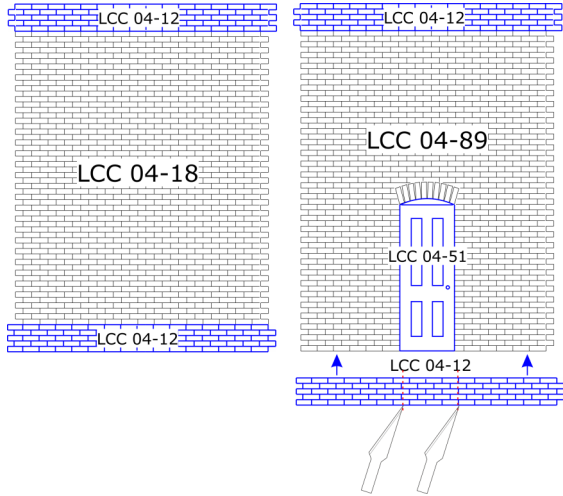

SIDE ELEVATIONS

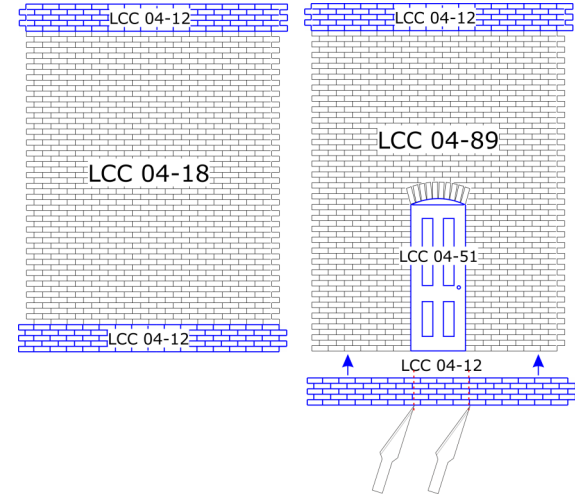

WATER TANK

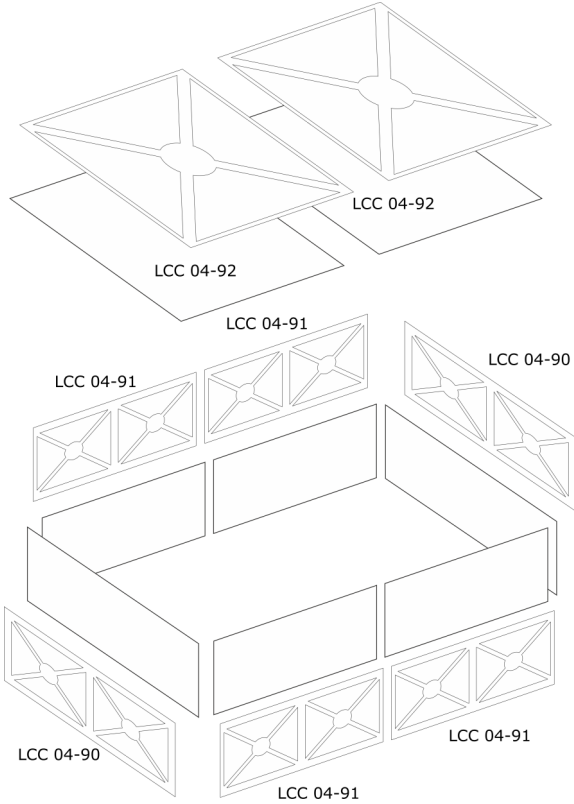

WATER TANK

