

# LCC Modelling System

## B 00-10 Bundle: medium double track engine shed with round windows

Bundle contains:

- 1x LCC 00-00
- 2x LCC 00-01
- 3x LCC 00-02
- 1x LCC 00-09
- 2x LCC 00-24A
- 2x LCC 00-24B
- 2x LCC 00-30
- 4x LCC 04-02
- 4x LCC 04-03
- 12x LCC 04-06
- 2x LCC 04-08
- 2x LCC 04-09
- 5x LCC 04-10
- 10x LCC 04-11
- 2x LCC 04-12
- 5x LCC 04-16
- 5x LCC 04-17
- 2x LCC 04-22
- 2x LCC 04-28
- 4x LCC 04-29
- 2x LCC 04-30
- 12x LCC 04-49

This kit includes elements which can be used to assemble a medium engine shed.

Footprint:

Width: 137mm

Length: 274mm

For more instruction go to manual which you can download from our website [www.lcut.co.uk](http://www.lcut.co.uk)

**All drawings are not in scale.**

LCC Modelling System is flexible and you can make easy modification. Please visit our website at [www.lcut.co.uk](http://www.lcut.co.uk) to shop for additional LCC elements.

### SIDE ELEVATIONS

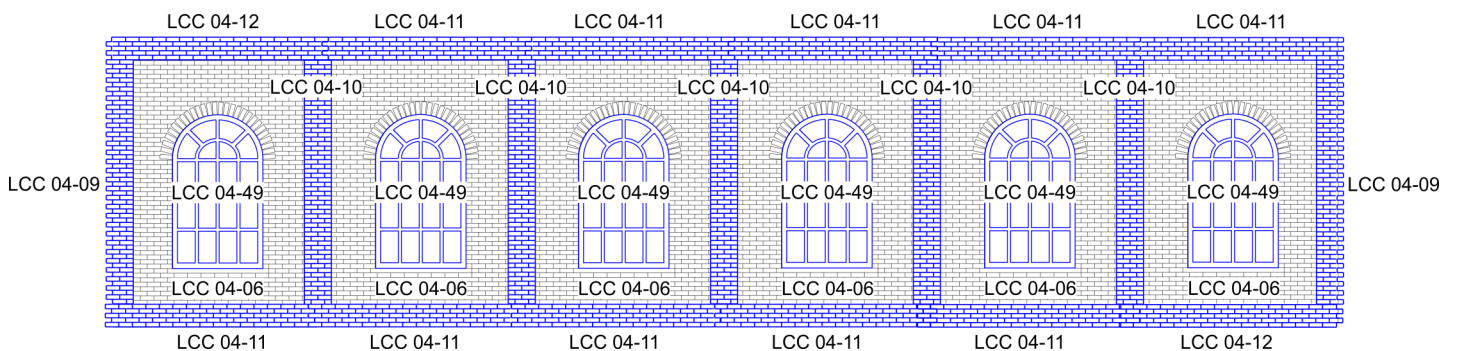

## DOOR ELEVATIONS

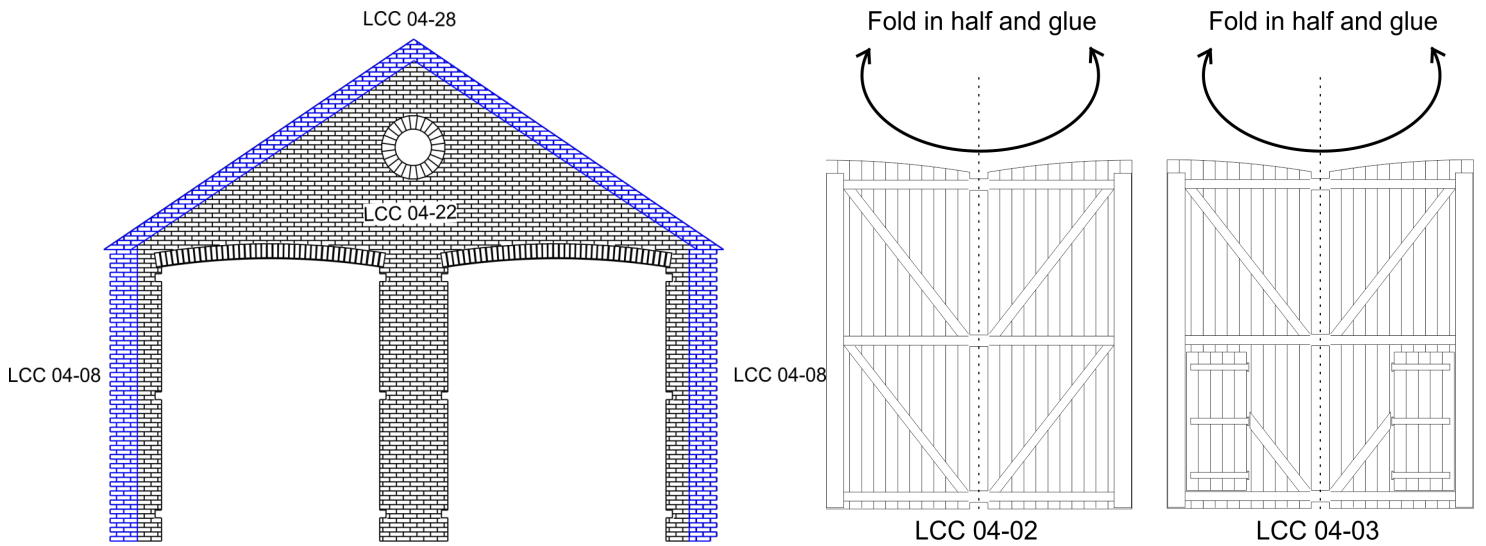

## ROOF ASSEMBLY

